

1 *Basic Rigging*

1.1 Introduction

Rowing is a sport that requires concerted motion between the athlete and the boat. To row effectively and to learn correct technique, it is clear that the boats and equipment must be properly adjusted and well-maintained. The construction of modern boats offers the possibility of individualised rigging to allow the coach to take into account the anatomical and physiological aspects of each athlete.

In this course, the terminology of the principal parts of the boat and equipment will be presented. You will be introduced to the basic adjustments and the tools necessary to make the adjustments. Also, guidelines for the proper care and repair of the materials will be presented to assist in prolonging the life of the boat and equipment.

By the end of this course you will learn that the basic adjustments are easy to accomplish with the knowledge of the necessary measurements and a few simple tools. You, the coach, will then be able to provide the athletes with properly adjusted boats and equipment, which will allow the athletes to increase the benefits of training.

1.2 Measuring aids and tools

It is necessary in the beginning to acquire a few simple measuring aids and tools to be able to make the adjustments on the boat and equipment. They are as follows:

- 1m length of string,
- straight piece of wood, 1.5m in length,
- tape measure or measuring stick,
- screwdriver,
- set of wrenches (10mm, 11mm, 13mm and 17mm),
- spirit level.

It is important to keep these measuring aids and tools together in a kit or tool box as this will ensure that time is not lost in searching for missing items.

1.3 Terminology

The sport of rowing is divided into two distinct categories: sculling and sweep rowing.

Sculling events require each athlete to use two oars, which are pulled simultaneously and range from the single sculls to the quadruple sculls. Sweep rowing events require each athlete to use one oar and range from boats containing as few as two athletes to as many as eight with one coxswain.

There are three types of sculling boats: the single, the double and the quadruple. These have one, two and four athletes, respectively. There are five types of sweep rowing boats: the pair with coxswain, the pair without coxswain, the four with coxswain, the four without coxswain, and the eight with coxswain. The pairs, of course, have two athletes per boat.

Generally, the terminology used in naming the part of the boat and equipment and the points of adjustment for sculling and sweep rowing are identical. However, to ensure that this terminology is standardised, figures 1 to 3 present the basic terminology for the parts of the oar (figure 1),

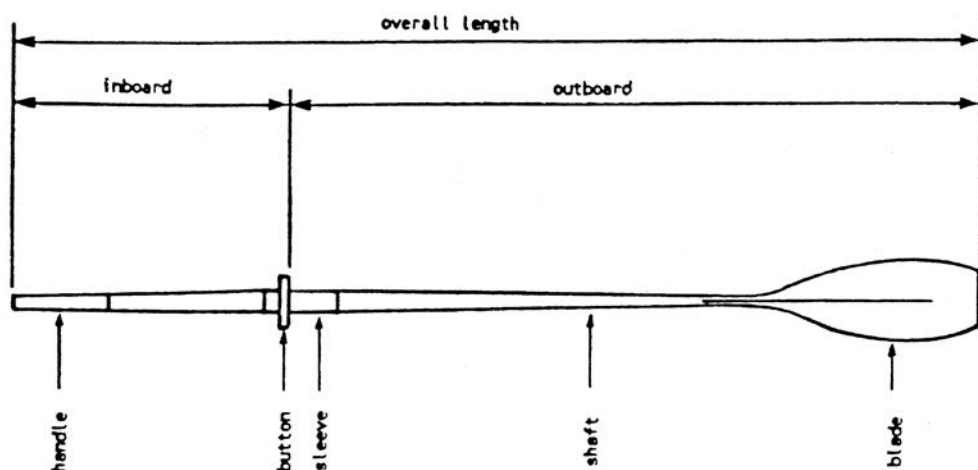

Figure 1 – Parts of the Oar

the parts and adjustment points of a sweep rowing boat (figure 2) and a sculling boat (figure 3).

The placement of the athlete in a boat, except in a single scull,

is generally designated by a numbering system that commences with the number one for the seat closest to the bow and continues to the number that corresponds to the seat position closest to the stern. The first and last seat positions may also be designated bow and stroke, respectively.

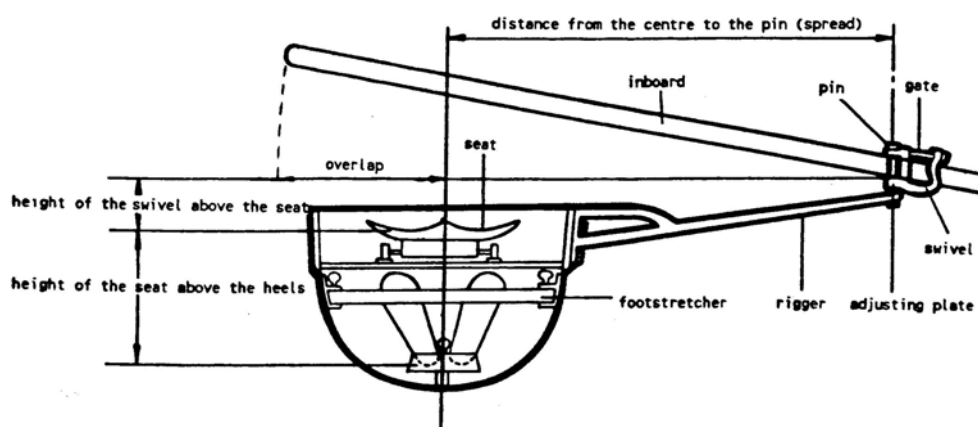

Figure 2 – Parts of a sweep boat

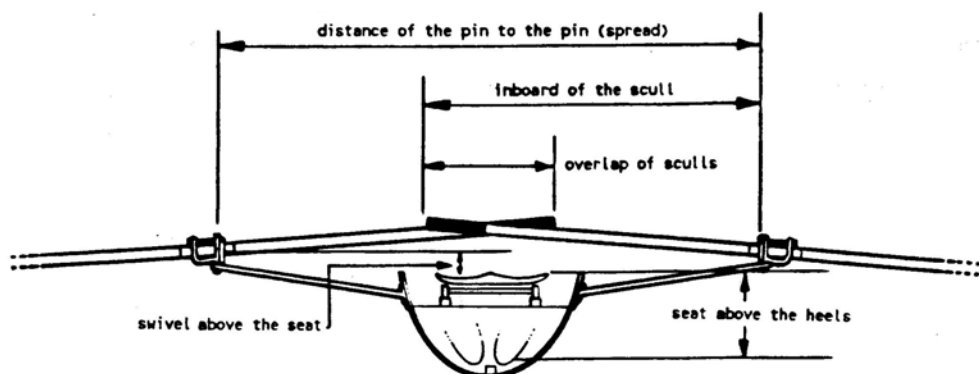

Figure 3 – Parts of a sculling boat

The oars may be identified by seat placement and the rowing side by the use of a numbering system (similar to the system for the placement of the athlete) and by the use of a coloured tape or letter to designate the rowing side.

Generally, the letter “S” or red tapes identifies the stroke-side (the left side of the boat as viewed standing at the stern and facing the bow of the boat) and the letter “B” or green tape identifies the bow-side (the right side of the boat as viewed standing at the stern and facing the bow of the boat).

1.4 Adjustment of boats and equipment

In theory, the adjustments to the boats and equipment are the same for either type of boat, sculling or sweep. This section will present the information necessary to prepare a rowing boat.

Length and placement of the tracks

The length of the tracks can vary from 65cm, in the old boats, to 85cm, in extreme cases. The normal length is between 70 and 75cm. The tracks (see A in figure 4) are generally placed in a position that allows at least 65cm between the extreme bow end of the tracks to a line that is perpendicular to the boat at the position of the working face of the swivel.

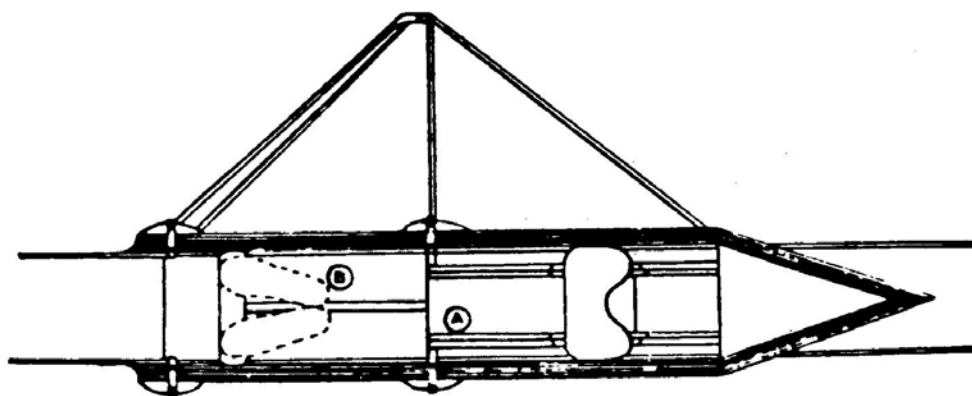

Figure 4 – Placement of the tracks

Angle, height and placement of the foot stretcher

Although in many boats the angle and height of the foot stretcher are fixed by the boat builder, it is important to obtain a good position for the athlete which allows free and comfortable movement.

Therefore, in most new boats the angle and height of the foot stretcher are adjustable.

It has been found that a good position for the angle of the foot stretcher (see figure 5) is between 38 and 42 degrees. It has also been found that a good position for the height of the foot stretcher (the vertical distance from the seat down to the heel of the foot stretcher, see figures 2 and 3) is about 15cm to 18 cm.

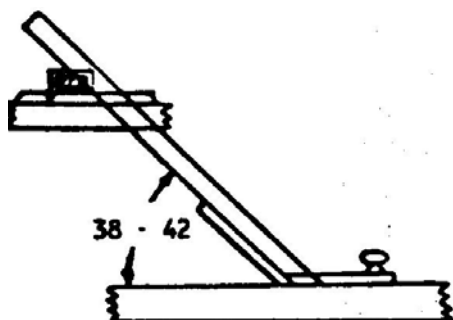

Figure 5 – Angle of the foot stretcher

The placement of the foot stretcher is important because it controls the position of the oar at the entry and finish. Therefore, consideration must be given to the rowing technique utilised by the athlete and the athlete's position in relation to the working face of the swivel. Further, in all boats, the correct placement of the foot stretcher must ensure a correct and uniform finish position.

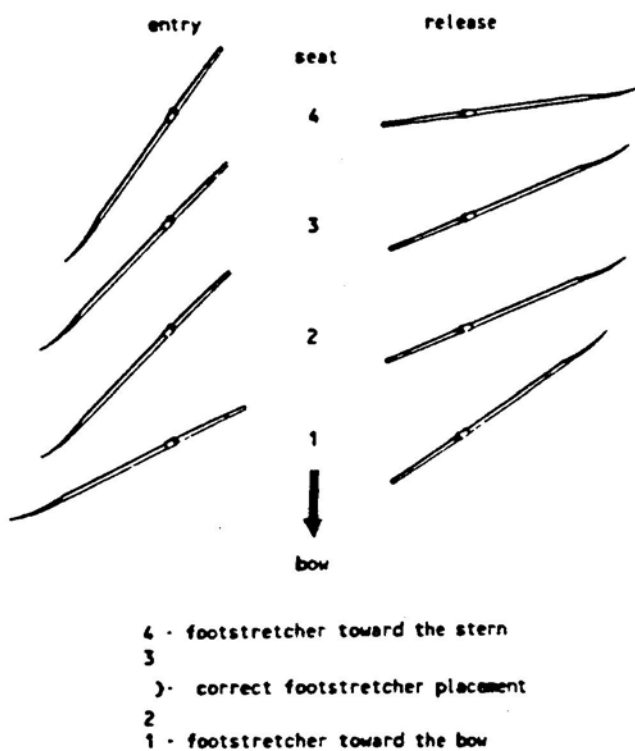

Figure 6 – Placement of the foot stretcher

The effect of the placement of the foot stretcher is demonstrated in figure 6. The athlete in the top of the drawing has the foot stretcher placed too close to the stern of the boat and the athlete in the bottom of the drawing has the foot stretcher placed too close to the bow of the boat.

The athletes in the middle positions of the drawing have the foot stretchers placed in the correct position.

Spread in sculling and sweep rowing

Pin-to-pin distance in sculling

In a sculling boat, the place of measurement of the spread is from the centre of the pin of one rigger to the centre of the pin of the rigger directly opposite. This distance is usually measured within the range of 156cm to 160cm (see figure 7). It should be noted that it is important to ensure that each pin has the same distance from the centre of the boat.

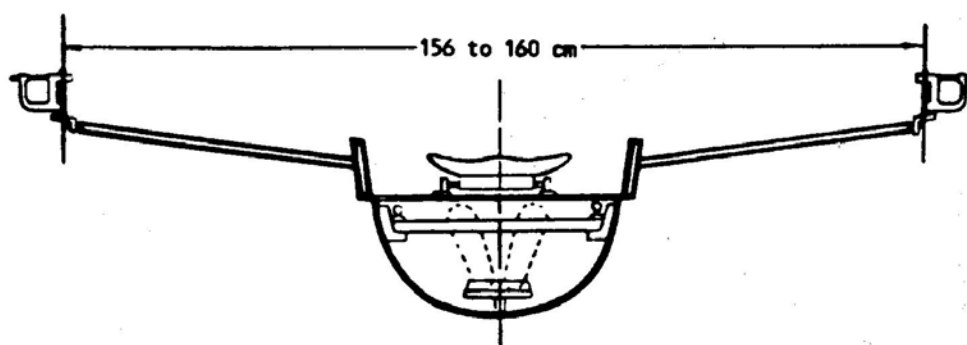

Figure 7 – Measuring the distance from pin to pin

Distance of the pin from the centre in sweep rowing

The place of measurement of the spread in a sweep rowing boat is different. The usual practice is to measure the distance of the pin from the centre of the boat on a line drawn perpendicular from the pin to a line extending lengthwise down the centre of the boat.

This distance varies from boat to boat because it is dependent upon the size and strength of the crew and the type of boat.

Use the following procedure to adjust the distance of the pin from the centre for each seat in a sweep rowing boat:

- 1 Measure the width of the boat at the point perpendicular to the pin (see 1 in figure 8).

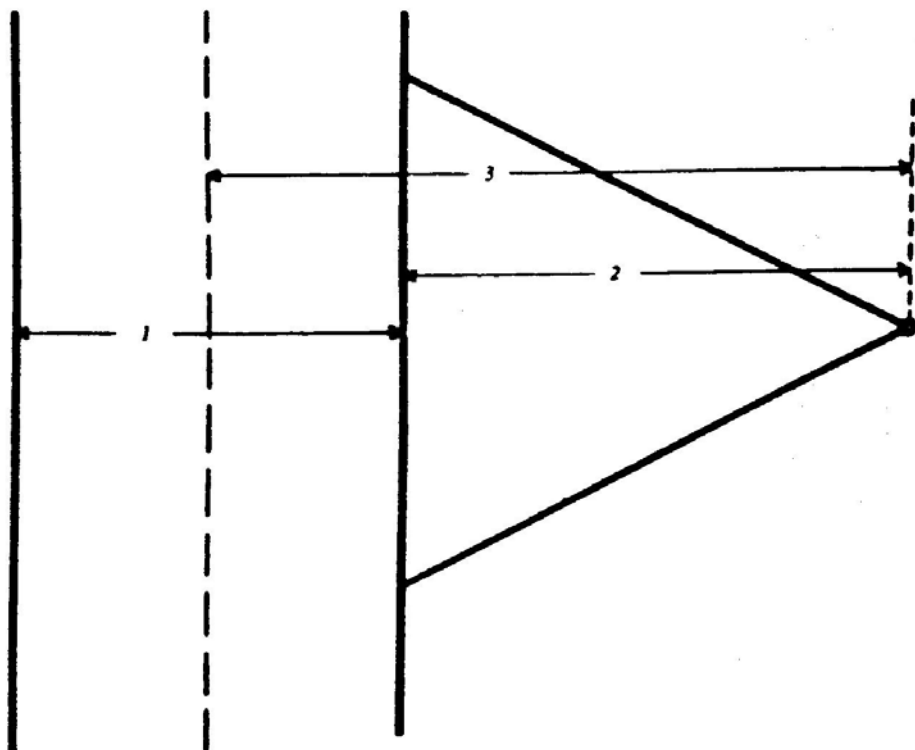

Figure 8 – Measuring the distance from the pin to the centre of the boat

- 2 Determine the distance from the edge of the boat to the centre of the pin (see 2 in figure 8).
- 3 The result of measurement 2 added to one-half of measurement 1 will provide the measure of 3 (see figure 8) which is the distance of the pin from the centre of the boat. This distance is usually measured within the range of 80cm to 90cm (see figure 9).

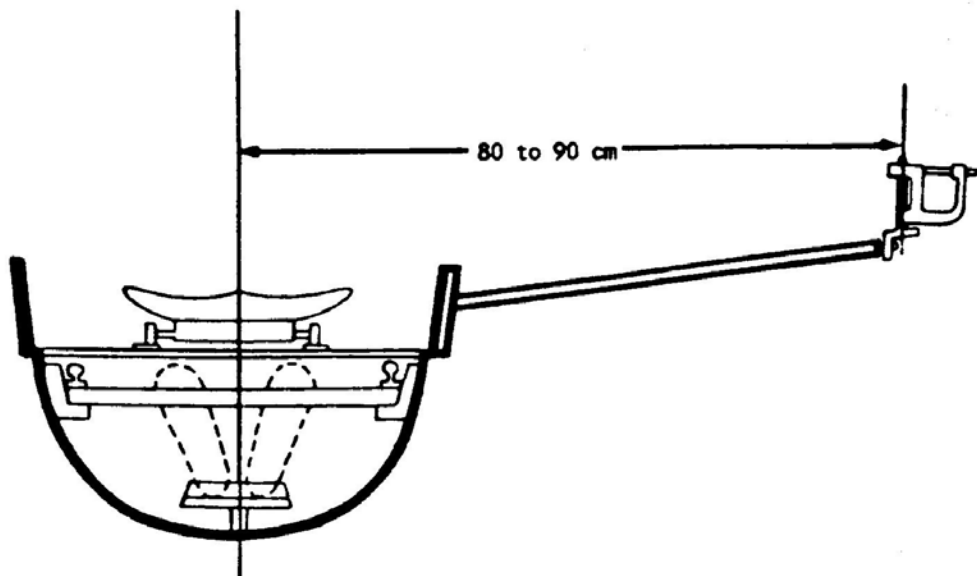

Figure 9 – A standard measurement

Height of the swivel

The height of the swivel is measured identically in sculling and sweep rowing boats. The height is the measure of the vertical distance from the lowest point of the seat to the top of the sill (or horizontal arm) of the swivel (see figure 2).

The height of the swivel is generally measured by placing the board across the gunwales of the boat at a position that is perpendicular to the swivel and measuring down to the seat and up to the swivel, both measured from the top face of the board. The point of the seat you choose to use should be consistently used from boat to boat as your reference point. These two measurements are then added to provide the measurement of height. The height is generally measured within the range of 16cm to 18cm.

The height may be changed by either raising or lowering the rigger on the boat or by altering the height of the swivel on the pin by the removal or addition of washers or spacers above or below the swivel.

Placement of the button on the oar

The sculls and sweep oars are both divided into two parts by the position of the button. These two parts are termed the inboard and the outboard (see figure 1). The position of the button may be changed simply by loosening the nuts and bolts that secure the button to the oar, moving the button either towards or away from the blade, and tightening the nuts and bolts. Although it is important to have the correct outboard distance, the measurement for the correct position of the button is generally from the end of the handle or grip to the face of the button nearest the blade, the inboard distance.

The inboard distance is usually measured within the range of 85cm to 90cm for sculling oars and 110cm to 118cm for sweep oars, depending on the overall length of the sculls or sweep oars.

Pitch of the blade

This section will explain the measurement and adjustment of the pitch of the blade. The pitch of the blade is a measure in degrees of the inclination of the blade towards the stern of the boat during the drive phase of the stroke cycle.

It is important, in the beginning, to level the boat, both across the width of the boat and along the length of the boat (see figure 10).

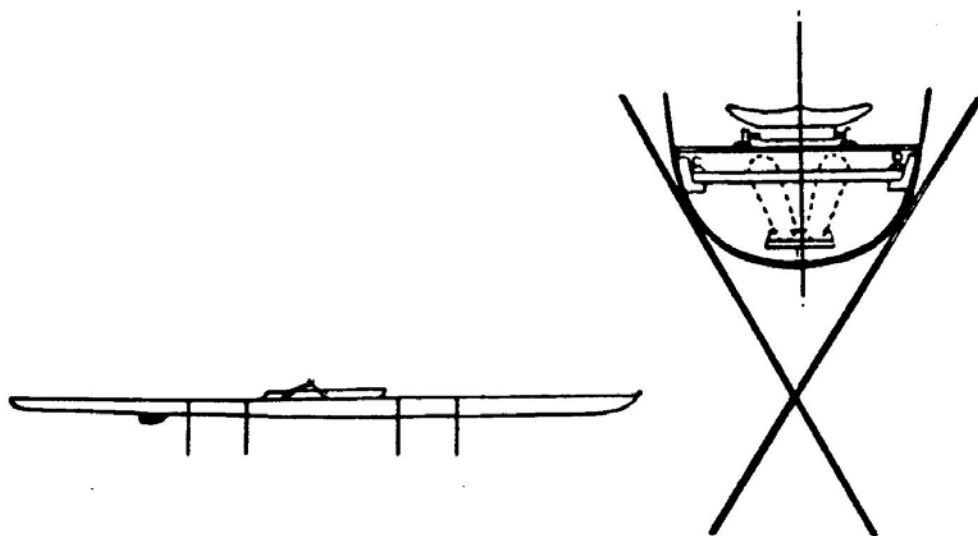

Figure 10 – Level of the boat

Next, it is necessary to check the angle of the pin. The pin should be vertical in all planes: outward and inward (the lateral angle) and the forward and backward (the stern angle).

Although the pin may be inclined outwards (and should never be inclined inwards), it has been determined, for the purposes of this course, that the lateral angle be zero degrees. This position will maintain the same pitch of the blade from the entry to the finish positions of the stroke cycle. It will be explained in the Level II course of the FISA CDP that experienced athletes should use an outward lateral pitch of about one to two degrees. The purpose of this adjustment and the procedure to make the adjustment will also be explained in that course.

As the stern angle of the pin (the forward and backward inclination) should be zero degrees, the pitch of the blade is determined by the sum of the angle of the working face of the swivel and the angle of the flat back of the shaft or working face of the oar.

Generally, the working face of the swivel has a forward angle of four degrees while the working face of the oar has a forward angle of zero to four degrees. Depending on the choice of oars, this would result in a pitch of blade between four and eight degrees.

It is recommended that the pitch of the blade be about eight degrees for novices or beginners. As the athlete improves in technical proficiency, the pitch of the blade may be decreased. The amount of the decrease is also dependent upon the event or type of boat. Further information on decreasing the pitch of the blade will be presented in Level II of the FISA CDP.

Next, it is necessary to measure the pitch of the blade. To measure the pitch of the blade:

- 1 Place the oar in the swivel and have an assistant firmly hold the flat back of the shaft or working face of the oar at the button against the flat or working face of the swivel.
- 2 Place the oar perpendicular to the boat and hold it at a level comparable to its depth in the water.
- 3 Place a weighted string over the top of the blade, at a point 5cm from the tip of the blade and allow it to hang in front of the blade until stable.
- 4 Measure the horizontal distance between the bottom edge of the blade and the hanging string (see figure 11).
- 5 Measure the width of the blade at the point 5cm from its tip.
- 6 With these two measurements, refer to the chart shown in Appendix B to determine the pitch of the blade.

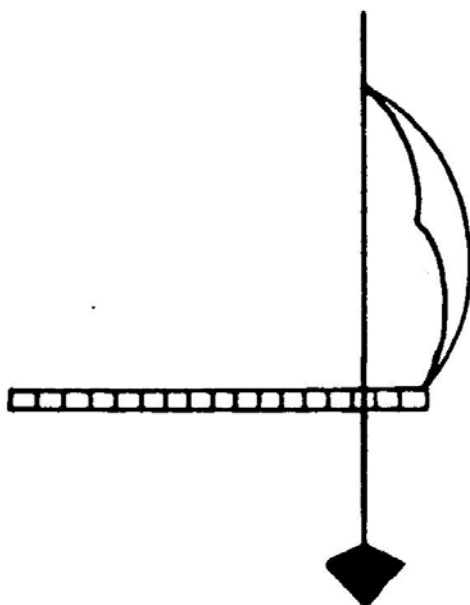

Figure 11- Measuring the pitch of the blade

The desired pitch of the blade may be obtained by a simple adjustment of the equipment. Generally, this adjustment is made by either changing a plate on the face of the swivel or by loosening the locking devices on the swivel assembly and making the appropriate adjustment. In regard to the latter adjustment, it is preferable that the adjustment not alter the vertical position of the pin. With modern swivels: inserts with different degrees can be changed to adjust the inclination.

Summary

This section has provided you with the basic knowledge of rigging the boat and its equipment. The standard procedure presented in Appendix A provides a convenient checklist for the preparation and adjustment of the boat and equipment.

1.5 Basic equipment care

Proper care of the equipment is extremely important if the equipment is to function properly over a number of years. As the coach, your attitude towards the care of the equipment is reflected by the athletes. A talk to the athletes at the beginning of the year and intermittent discipline during the year can ensure that the athletes treat the equipment with respect. Besides, proper care of the equipment is the best preventative medicine available to prevent breakage during racing.

Maintenance

The boats and oars should be cleansed with water after every training session. Salt water and chemicals in lakes, rivers and bays can corrode the materials of the boat. Proper cleansing with fresh water can retard this deterioration. Tracks, seat wheels and swivel pins should be cleansed and lubricated at least once a week during your training season.

It should be noted that the common practice of adding grease or petroleum jelly to the swivel, to allow the oar to be turned more easily, may allow sand and other particles to accumulate causing damage to the swivel and oar. Therefore, the grease or jelly should be removed and replaced regularly.

The following is a list of possible trouble areas that should be examined and corrected prior to the problem becoming more serious and causing further damage to the boat and its equipment.

Possible trouble areas:

- 1 Worn swivel
- 2 Loose-fitting rigger components
- 3 Loose nuts and securing devices
- 4 Badly worn buttons or sleeves on the oar
- 5 Oar too loose or too tight in the swivel
- 6 Badly worn tracks
- 7 Badly worn seat wheels and axles

Simple repairs of wooden material

Even with the best preventative medicine there will still be equipment wear and deterioration. When breakage occurs, it will most likely occur during a training session on the water. The coach should be prepared with a toolbox containing the appropriate spare parts: swivels, pins, buttons, nuts, bolts and screws. These parts should be in the same kit as your rigging tools.

If there is an accident during training, such as colliding with floating debris or another boat, you can minimise the potential damage with some simple first aid. First, retrieve any shattered or splintered parts from the water to use later in the repair. Second, clean and dry the area around the crack, if not severely damaged. Third, cover the crack with some waterproofing tape. This will minimise the contact of the wood with the water and, thereby, reduce decay. However, if major damage occurs, head directly for land and get the boat out of the water to minimise exposure to the water.

After training, the crack should be properly repaired. The boat builder can recommend the best glue to use for repair. The glue is placed on both sides of the crack and the two sides are pressed together until the glue is dry. The repaired area is then covered with varnish to provide waterproofing protection.

The same procedure is also necessary for wooden oars. Any scratches or punctures should be dried, sanded and varnished. The coach should be prepared for all this maintenance because good care of the material is required to preserve the basic elements of his passion: the boats and the oars.

For more information about repairs and maintenance, as well repair of composite boats, oars and sculls, see “Guide for Maintenance and Repair of Rowing Equipment”, produced in 1999 by the former FISA Material Commission, now entitled the FISA Equipment and Technology Commission.

1.6 Appendices

Appendix A

Standard procedure for the preparation and adjustment of the boat and equipment

- 1 Place the boat on suitable supporting structures in an open-working area.
- 2 Clean the boat and its equipment.
- 3 Check all moving parts on the boat.
- 4 Check and secure the rigger bolts.
- 5 Check and secure the position of the tracks.
- 6 If the angle and the height of the foot stretchers are adjustable, make the appropriate adjustments.
- 7 Set the pin-to-pin distance the distance between the pin and the centre of the boat and mark the position with a marker or tape.
- 8 Set the desired height of the swivel.
- 9 Set the inboard or outboard on the oar.
- 10 Level the boat lengthwise and sideways.
- 11 Place and hold the oar firmly in the swivel and perpendicular to the boat. With the blade at the correct height, set the pitch of the blade.
- 12 Re-check the height of the swivel.
- 13 Check the locking devices on the swivel.
- 14 Check that the swivel swings freely.
- 15 Check that all nuts and locking devices on the rigger are secure.
- 16 When the boat has been placed on the water, check that the foot stretchers are properly set to ensure a correct and uniform finish position.

Appendix B

Table for measuring the pitch of the blade:

Blade	Degrees				
cm	4	5	6	7	8
13	9.1	11.3	13.6	15.8	18.2
14	9.8	12.2	14.6	17.1	19.6
15	10.5	13.0	15.7	18.3	21.0
16	11.2	13.9	16.8	19.5	22.4
17	11.9	14.8	17.8	20.7	23.7
18	12.6	15.6	18.8	21.9	25.0
19	13.3	16.5	19.9	23.2	26.5
20	14.0	17.4	20.9	24.3	28.0
21	14.7	18.3	21.9	25.5	29.5
22	15.4	19.2	22.9	26.7	31.0
23	16.1	20.1	23.9	27.9	32.5

Appendix C

Table of recommended measurements

Club level – Macon blade – all measurements in centimetres (cm)

Sculling	Spread	Outboard	Inboard	Length	Overlap
Men	158-160	212-210	86-88	298	18-22
Women	156-158	211-209	85-87	296	18-22

Club level – “Big Blade” – all measurements in centimetres (cm)

Sculling	Spread	Outboard	Inboard	Length	Overlap
Men	158-160	204-202	86-88	290	18-22
Women	156-158	200-202	86-88	288	18-22

Sweep Rowing:

Club level – Macon blade – all measurements in centimetres (cm).

Boat	Spread	Outboard	Inboard	Length	Overlap
Men					
2-	87	265	117	382	30
2+	88	264	118	382	30
4-	85	267	115	382	30
4+	86	266	116	382	30
8+	84	268	114	382	30
Women					
2-	86	264	116	380	30
4-	85	265	115	380	30
8+	84	266	114	380	30

Club level – “Big Blade” – all measurements in centimetres (cm)

Boat	Spread	Outboard	Inboard	Length	Overlap
Men					
2-	87	257	117	374	30
2+	88	256	118	374	30
4-	85	259	115	374	30
4+	86	258	116	374	30
8+	84	260	114	374	30
Women					
2-	86	256	116	372	30
4-	85	257	115	372	30
8+	84	258	114	372	30